



Water Coolers



COMPACT FLOOR STANDING WATER COOLER

P10CP

Suggested Specification

Pressure drinking water cooler shall deliver at least 10.0 gph of water at 50°F (10°C) cooled from 80°F (26.7°C) inlet water at 90°F (32.2°C) ambient. Bubbler shall have flexible guard, have a non-squirt feature and a lever handle shall activate water flow. Bubbler shall provide smooth steady water flow by means of integral regulator that operates from 20 to 120 PSI supply pressure. Evaporator shall be high efficiency tank type and shall be encapsulated in insulation. R-134a refrigeration system shall be hermetically sealed and refrigerant flow shall be capillary tube controlled. An adjustable thermostat having an off position shall control refrigeration system. Stainless steel top shall have an integral drain strainer. Exterior panels shall be powder coated galvanized steel (standard finish) or stainless steel (optional finish). Potable water system components shall comply with the Safe Drinking Water Act Amendments, the 1988 Lead Contamination Control Act and shall be Certified to NSF/ANSI 61, Section 9. Chilled water capacity shall be rated per ARI Standard 1010. Cooler shall be Listed by Underwriters' Laboratories Inc. to U.S. and Canadian safety standards.

Model

P10CP delivers 10.0 gph of chilled drinking water

Standard Features

- > Waterways are Lead-Free in Materials and Construction
- > Bubbler with activation lever
- > Stainless steel top
- > Heavy-gauge steel cabinet with separate galvanized steel base
- > High-efficiency cooling tank and coil.
- > Refrigerant R-134a
- > Limited 5-Year Warranty

Finishes

- > Standard Cabinet Finish: Sandstone powder coated paint on galvanized steel
- > Optional finishes at additional cost: Stainless Steel and optional powder coated finishes.

Installation

- > Prior to roughing-in, consult local, state and federal codes
- > Shipped with complete instructions

Options

- > Push Handle 029603-004
- > Push Back 029603-005
- > Push Down 029603-006
- > Kit 031505-001 is required for Field Installation of the above glass fillers
- > Foot pedal operated



Components in this cooler are lead free as defined by the Safe Drinking Water Act Amendments of 1986, and the Lead Contamination Control Act of 1988.

Limited 5-Year Warranty (Continental limits of the United States and Canada): Five years on the sealed refrigeration system and most components parts. Detailed warranty certificate enclosed with each water cooler; sample copy available upon request.

Export Warranty: One year on sealed refrigeration system and most parts. Four-year replacement contract on sealed refrigeration system. Detailed warranty certificate enclosed with each water cooler; sample copy available upon request.

Product Certified to NSF/ANSI Standard 61, Annex G (weighted average lead content of <=0.25%) and is in compliance with California's Health & Safety Code Section 116875 (commonly known as AB1953).

Models covered by this specification comply with all known Plumbing Codes. Listed by Underwriters' Laboratories to U.S. and Canadian standards and European Union Directives.



Model	50° F Drinking Water 90° F Ambient Air Temp*				115 Volts, 60 HZ			Glass Filler Acc. Option	Cabinet Color Finish	Net Wt. Approx.
	Rated Capacity GPH	Base Rate GPH	Pre-Cooler	Hot 'N Cold™ Model	Compr. HP	Full Load Amps	Rated Watts			
P10CP**	10.0	10.0	No	No	1/4	4.4	500	Yes	Yes	70 Lbs.

Specifications subject to change without notice

* Industry Standard Rating Condition 80°F inlet water temperature.

** Special export models available, operable on 220-240 volts, 50/60 Hertz. cULus certification not applicable.

OASIS® FREE-STANDING WATER COOLER MODEL P10CP

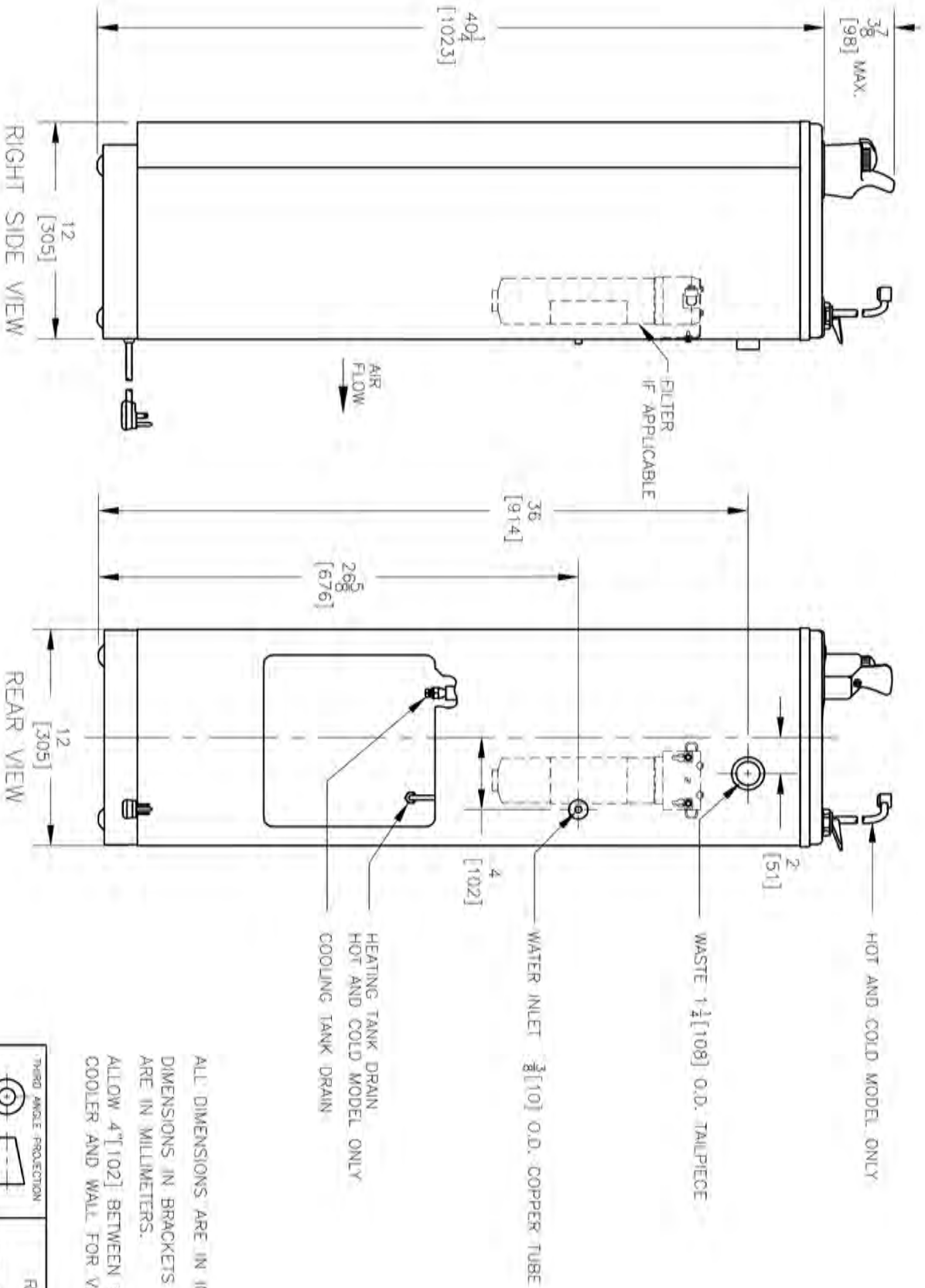

ALL DIMENSIONS ARE IN INCHES.
 DIMENSIONS IN BRACKETS []
 ARE IN MILLIMETERS.
 ALLOW 4" [102] BETWEEN REAR OF WATER
 COOLER AND WALL FOR VENTILATION.

THIRD ANGLE PROJECTION

 ROUGHING-IN
 AND
 DIMENSIONAL DRAWING